

TERMOFOL

HEATING MAT

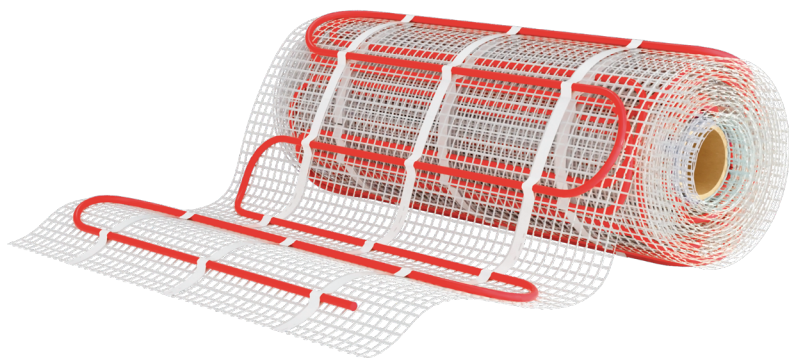

ZESKANUJ I OBEJRZY MONTAŻ
SCAN TO WATCH INSTALLATION



Installation manual **EN**



Note: Please read the instructions before starting the installation!

Dear Madam or Sir,

Thank You for purchasing a TERMOFOL heating mat. We are convinced that you will be satisfied with our product. At any time, we offer our assistance and we are willing to provide information, both during an assembly, and operation of our products. Please, feel invited to visit our web site at www.termofol.pl.

Technical data of TERMOFOL heating mats

- Rated power of mat: 150W/m²
- Power voltage: 230V +/- 15% 50/60Hz
- Width: 50 cm
- Length: surface in m² x2
- Mat power supply: One-sided
- International Protection Rating: IPX7
- Thickness of heating conductor: 3.6 mm²
- Bearing base floor: Glass fibre mesh – self-adhesive
- **25-year warranty**

Restrictions and general notes

- You should wear shoes with a soft rubber sole while performing the assembly operations.
- Special caution should be exercised while assembling a heating mat and finishing a floor.
- **IN NO CIRCUMSTANCES YOU ARE ALLOWED TO SHORTEN THE HEATING CONDUCTORS.**
- A heating mat must be connected to a thermostat.
- The heating conductors cannot overlap and in the case of an assembly without any mesh – keep a distance of 9cm between the conductors.
- Do not use any sharp tools while assembling a mat.
- It is forbidden to connect a heating mat to wiring without any thermostat on a permanent basis.
- You should clean, level and prime a room base floor.
- An assembly of a heating mat is permitted at the temperature of above 5 °C.
- You should execute three measurements of heating conductor and insulation resistance.
- Draw up w wiring sketch and complete data from the measurements (tolerance of +/- 10%)
- If it is necessary to extend the power supply conductors of a heating mat, you should provide a connection according to the electrical requirements.
- You should observe the safety provisions in respect of an assembly of an electric heating in the rooms with increased humidity (washroom, toilet, bath room) and in the zone 1 of anti-shock protection.
- Install a heating mat minimum 10 cm from the vertical walls.

Draw up a design how to arrange a heating mat considering the fittings of sanitary whiteware (bathtub, shower tray, toilet bowl, bidet, etc.). Use an elastic adhesive with a plasticiser for the floor electric heating for an assembly of the ceramic tiles. Make sure if your wiring has residual current protection (A). If not, execute a residual current protection. Do not install heating mats under the fixed joinery (furniture, washing machines, refrigerators, etc.)

AN ELECTRICAL WIRING CONNECTION MUST BE MADE ONLY BY AN ELECTRICIAN WHO HOLDS A VALID SEP (ASSOCIATION OF POLISH ELECTRICAL ENGINEERS) QUALIFICATION CERTIFICATE!

Protection zones and safety rules

The Construction Law clearly specifies the safety zones applicable in the washrooms and bath rooms. It is absolutely required to observe the rules related to an assembly of the electric devices in the above-mentioned rooms!

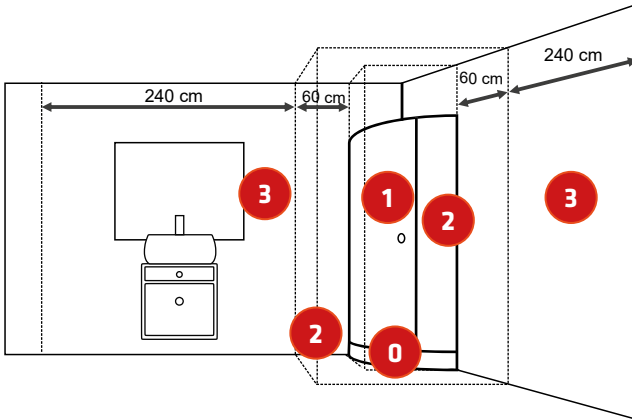

Safety zones:

- **Zone 0** – A zone measured along an external outline of the base floor in a site where a bath tub, a shower tray, a shower stall, an open stall is assembled-IT IS FORBIDDEN TO ASSEMBLY THE HEATING MATS AND A THERMOSTAT.

- **Zone 1** – A zone measured along an external outline of a bath tub, a shower tray, a shower stall, an open stall from a base floor to a height of 2.25 m – IT IS FORBIDDEN TO ASSEMBLY THE HEATING MATS AND A THERMOSTAT.

- **Zone 2** – A zone measured from an external outline of a bath tub, a shower tray, a shower stall, an open stall up to 60 cm from the above- mentioned items to a height of 225 cm – IT IS ALLOWED TO ASSEMBLY THE HEATING MATS, BUT NOT A THERMOSTAT.

- **Zone 3** – A zone measured in a distance longer than 60 cm an external outline of a bath tub, a shower tray, a shower stall, an open stall up to an unlimited height of the room. IT IS ALLOWED TO ASSEMBLY THE HEATING MATS AND A THERMOSTAT.

■ WARNING!

ANY FAILURE TO ADHERE TO THE ABOVE-MENTIONED RULES EXPOSES THE USERS TO ELECTRIC SHOCK WHAT MAY RESULT IN A PERMANENT PERSONAL INJURY OR A DEATH. THERMOSTAT INSTALLED IN THE WASHROOM MUST FEATURE AN INTERNATIONAL PROTECTION RATING OF IP2!

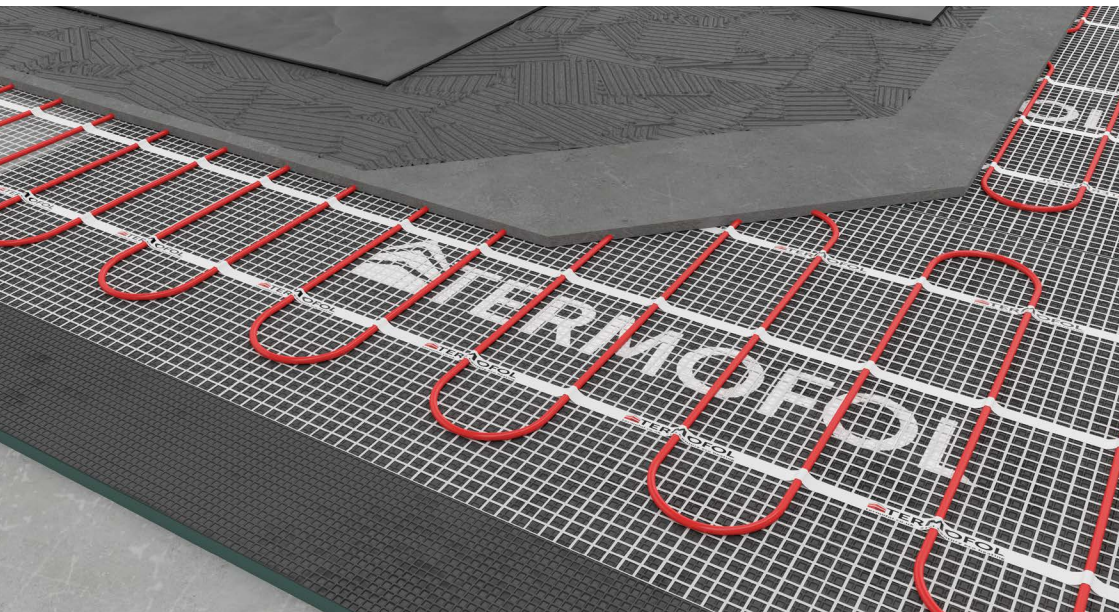

Exemplary design of an assembly of the heating mat in the washroom

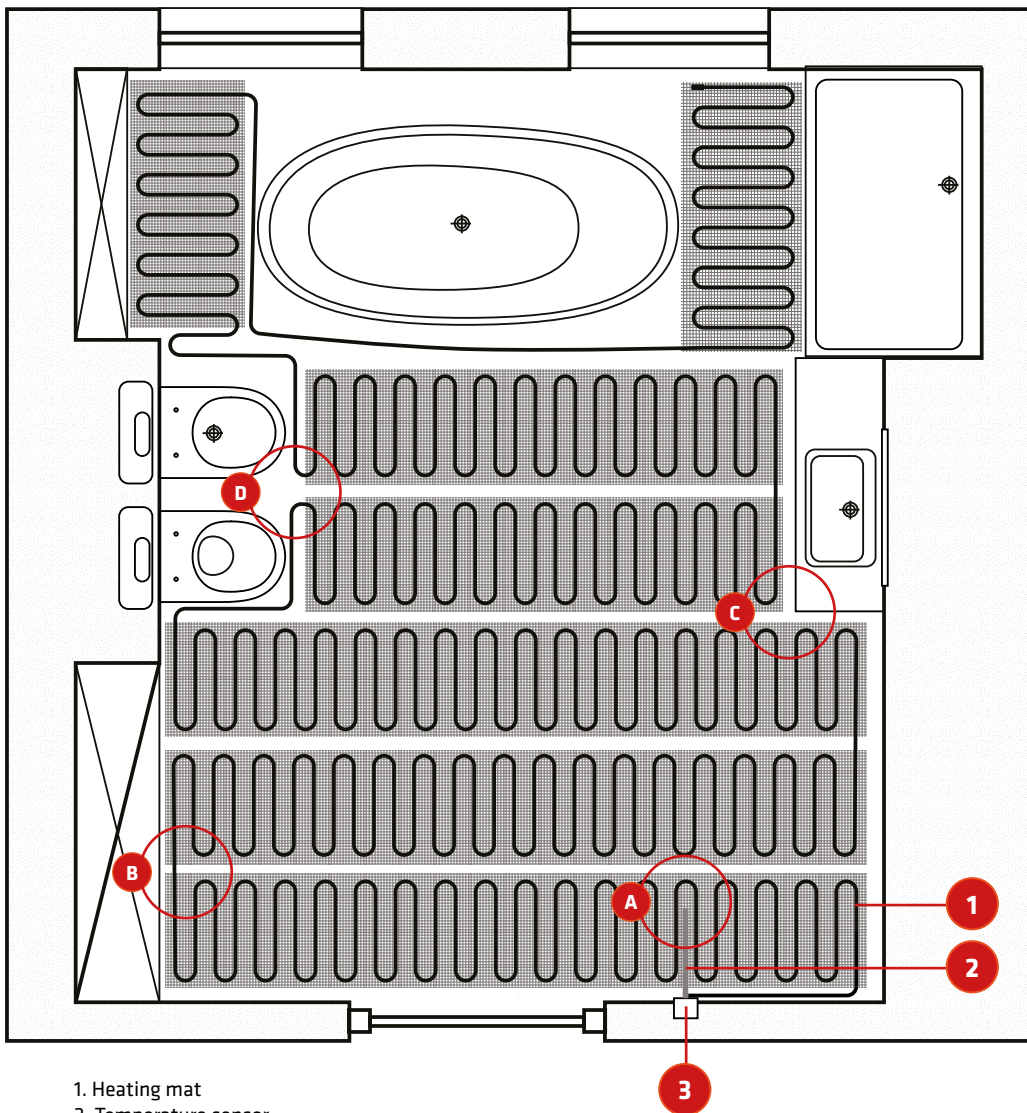

1. Heating mat
2. Temperature sensor
3. Thermostat

The rules, which are to be observed during an assembly

- A** - A floor temperature sensor has been assembled in the groove of a protective pipe, parallelly to the heating conductors. An end of the temperature sensor is in a half of the heating mat width what guarantees a correct temperature read-out.
- B** - An exemplary change of a direction of a heating mat arrangement by cutting out a base mesh.
- C** - The correct distances from a fixed joinery have been remained.
- D** - The correct distances from the sanitary fittings have been remained.

Thermostat installation

We distinguish two types of a thermostat installation in the washroom.

A – An assembly of a thermostat outside the washroom. A protective pipe of a temperature sensor has been provided on the external wall downwards, and then it has been introduced into a groove made in the flooring, under a heating mat.

If a controller features an International Protection Rating of IP 20, it must be installed pursuant to installation type A.

B – An assembly of a thermostat inside the washroom. A protective pipe of a temperature sensor has been provided on the washroom internal wall and a temperature sensor has been installed in the groove made in the flooring, under a heating mat. If a controller features an International Protection Rating of IP 21 it may be installed inside a room pursuant to installation type B.

1. Wall
2. Electrical wiring box
3. Thermostat
4. Protective pipe of floor sensor
5. Leading pipe bend support
6. Groove under floor sensor
7. Elastic adhesive
8. Ceramic tiles

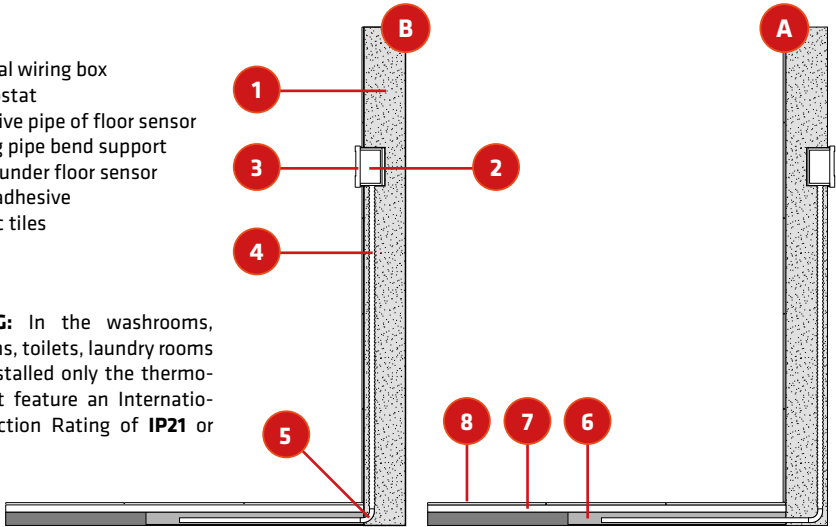

WARNING: In the washrooms, bath rooms, toilets, laundry rooms can be installed only the thermostats that feature an International Protection Rating of **IP21** or higher!

Cross-section of layers

1. Power supply line 230V
2. Thermostat
3. Pipe of floor sensor
4. Protective corrugated tubing with power supply conductors of
5. TERMOFOL heating mat
6. Ceiling
7. Floor thermal insulation
8. Floor self-levelling screed
9. Elastic adhesive for floor heating
10. Ceramic tiles

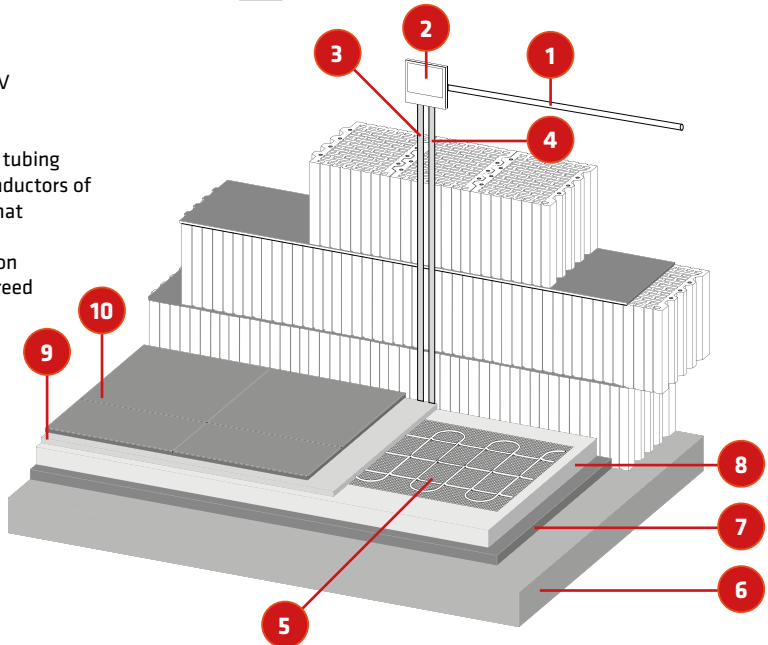

Assembly of electrical floor heating

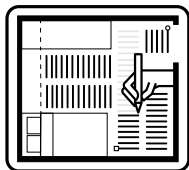

1. Design

It is an activity required to recognize and maintain a warranty, and at the same time a document that facilitates a diagnosis of the system.

Mark a site where a thermostat, a temperature sensor, power supply conductors in the design and draw up a plan of heating mat arrangement while considering the safety zones.

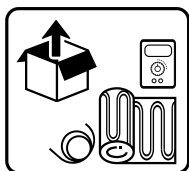

2. Product verification

Unpack the products from a package and prepare them for an assembly. Verify if you have the required tools.

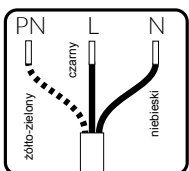

In the one-side powered heating mats a heating conductor consists of: **PN** - Earth conductor **N** - Neutral conductor **L** - Live conductor.

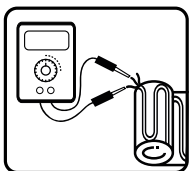

Execute the first resistance measurement of the conductor and lagging. Enter a result to a warranty card.

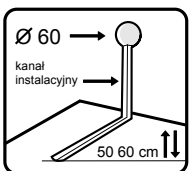

3. Installation preparation

Make a hole for an electrical wiring box, and then an installation duct up to a floor sensor installation site in the flooring. The duct should have a doubled width on the wall in order to fit a protective corrugated tubing and a pipe of a floor sensor in it.

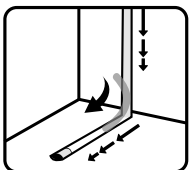

Install a protective pipe of a floor sensor, and then put a temperature sensor into it so that an end of the sensor reached an end of the pipe. Then insert a leading pipe bend support on a pipe and embed it in a groove.

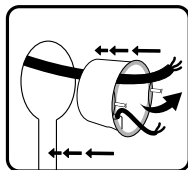

Insert power supply conductors of a house installation, conductors of a floor sensor, and then embed the box in the executed hole. Be careful not to damage the conductors of the temperature sensor.

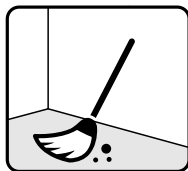

Eliminate all contaminations from the room, level the existing irregularities, and then prime the floor surfaces with a primer.

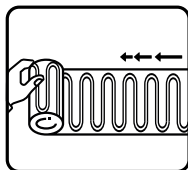

4. Mat installation

Roll out a mat, wait approximately one hour as an assembly mesh requires preliminary straightening.

Begin an arrangement of the heating mat while using a formerly prepared design.

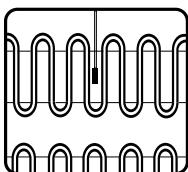

Arrange a mat in a site where a floor temperature sensor is assembled so that the sensor is between two heating conductors. It is of great importance to maintain the equal distances between the conductors.

A distance of the sensor from the wall must be of 40-60 cm. Remember to maintain a 10 cm distance between the heating mat and the walls. In the case when it is necessary to wrap up a heating mat below can be found three manners of its correct arrangement.

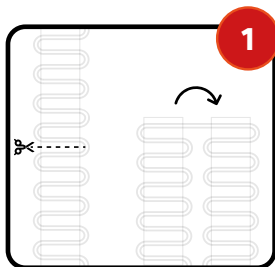

Parallel curl

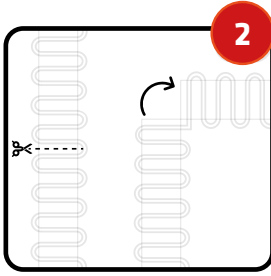

Right angle curl

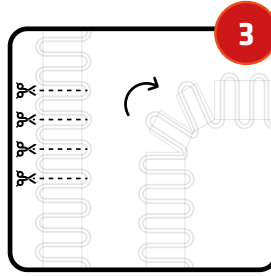

Wrap with a wide arch

WARNING!
IT IS FORBIDDEN
TO SHORTEN A HE-
ATING CABLE!

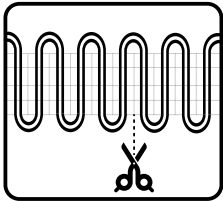

In any case shaping of a heating mat consists in extending a base mesh without compromising a heating cable.

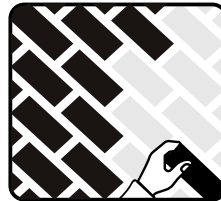

6. Floor finishing

Assembly the ceramic tiles arranging them on an adhesive layer with a thickness of 5–8mm. Exercise a special caution.

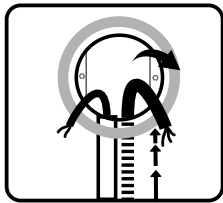

Upon arranging a heating mat according to a plan, insert a power supply conductor to a protective corrugated tubing and lead it to a box, then cut out appropriately.

WARNING! It is forbidden to clean the grout gaps with the sharp tools in order not to damage the heating conductors. **WARNING!** Do not cut out, put on or break the tiles directly on the floor with a glued heating mat.

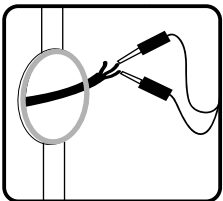

Upon inserting a conductor, make the second measurement of resistance of a heating mat. Enter a result to a warranty card.

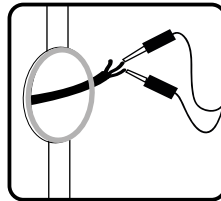

Upon finishing a floor and an adhesive curing, perform the third measurement of resistance of the heating mat. Enter a result to a warranty card.

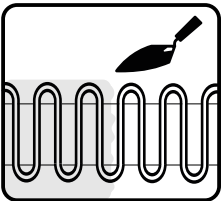

5. Mat gluing

Cover a rolled-out mat with an even layer of an adhesive mortar so that the heating conductors are precisely covered with the mortar adhesive.

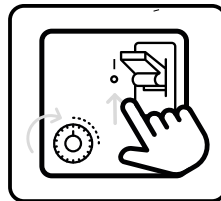

7. Thermostat connection

Make a thermostat connection according to a diagram included in the assembly manual.

Leave the preliminary glued heating mat for 24 hrs. in order to dry it out. **WARNING!** Use only an approved elastic adhesive for floor heating. Apply it with a plastic trowel. **IT IS FORBIDDEN TO USE METAL TROWELS!**

WARNING! A connection of a heating mat and a thermostat can be made only by an electrician who holds a valid certificate. Electrical qualification certificate!

WARNING! An installation must be secured by a residual current circuit breaker!

The first start-up

1. The first start-up should be performed after 25 days upon finishing a heating layer.
2. The first start-up lasts for 5 days. On the very first day, it should be adjusted to 19 °C, and then on each subsequent day increase a temperature by 1 °C until reaching 24 °C.
3. Upon an expiry of 5 days, the heating installation is ready to be used.

Obligations of installer and user

1. You should adhere to the provisions included in this assembly manual and recommendations.
2. An installer that performs an assembly of a heating mat is obliged to hand-over an assembly manual and the completed and signed warranty card to a user. The installer is obliged to enter a number of the SEP (Association of Polish Electrical Engineers) qualification certificate and make an actual plan of an arrangement of a heating mat.
3. It is forbidden to screw, cut, drill, hammer and execute the other construction works in a site where the heating mat is assembled.
4. In the case of a replacement of the floor ceramic tiles, the heating mats may be a subject of damaging. The enterprise that performs the construction works is responsible and liable for damaging the heating mats.
5. Remember to place furniture featuring a fixed joinery on the heating surface. In the case of the furniture assembly use the feet with a min. height of 3 cm.
6. Do not cover a floor with the carpets with a thickness larger than 8 mm
7. A user is obliged to store the assembly documentation and a proof of purchase.
8. Do not remove the labels – tags, which are on the TERMOFOL heating mats.

■ WARNING!

Fulfilling the above described and mentioned recommendations during the works related to an installation of a heating mat is necessary to a favorable consideration to the possible claims within a warranty period of the TERMOFOL heating mats.



ZESKANUJ I OBEJRZYJ MONTAŻ
SCAN TO WATCH INSTALLATION

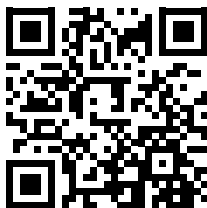

www.termofol.com



biuro@termofol.pl



+48 (12) 376 86 00

The logo for TERMOFOL, featuring a stylized red and white house icon to the left of the brand name "TERMOFOL" in a bold, sans-serif font.

HEATING MATS

TECHNICAL SPECIFICATION TABLE

Model	Heating area [m2]	Mat dimension	Power [m2]	The power of the mat	Amp	Ohms	Tension
TF-HM-150-05	0,5	0,5 x 1	150	75	0.35	601,2	230V
TF-HM-150-10	1	0,5 x 2	150	150	0.7	352,7	230V
TF-HM-150-15	1,5	0,5 x 3	150	225	1.0	235,1	230V
TF-HM-150-20	2	0,5 x 4	150	300	1.3	176,3	230V
TF-HM-150-25	2,5	0,5 x 5	150	375	1.6	141,1	230V
TF-HM-150-30	3	0,5 x 6	150	450	2.0	117,6	230V
TF-HM-150-35	3,5	0,5 x 7	150	525	2.3	100,8	230V
TF-HM-150-40	4	0,5 x 8	150	600	2.6	88,2	230V
TF-HM-150-45	4,5	0,5 x 9	150	675	2.9	78,4	230V
TF-HM-150-50	5	0,5 x 10	150	750	3.3	70,5	230V
TF-HM-150-60	6	0,5 x 12	150	900	3.9	58,8	230V
TF-HM-150-70	7	0,5 x 14	150	1050	4.6	50,4	230V
TF-HM-150-80	8	0,5 x 16	150	1200	5.2	44,1	230V
TF-HM-150-90	9	0,5 x 18	150	1350	5.9	39,2	230V
TF-HM-150-100	10	0,5 x 20	150	1500	6.5	35,3	230V
TF-HM-150-120	12	0,5 x 24	150	1800	7.8	29,4	230V
TF-HM-150-150	15	0,5 x 30	150	2250	9.8	23,5	230V
TF-HM-150-200	20	0,5 x 40	150	3000	13.04	17,63	230V